

12 Volt DC pumps

ddc

Laing supplies pumps for the world's first mass produced water-cooled workstation!

- Quiet
- Compact
- Powerful
- Durable
- Maintenance-free
- Low power consumption



LAING

simply the best • by design

12 Volt DC pumps

ddc

Application

The Laing DDC is the world's first pump to be used in mass produced water-cooled workstations, and presents an ideal solution for liquid cooling of processors and electronic components. Besides a lot of Online-Mentions, the Laing DDC is also awarded with the Innovation Award of Baden-Württemberg, known as one of the most innovative regions in Germany and Europe. Due to its size and output, the Laing DDC can also be used in a large number of applications.

Design

The Laing DDC is an electronically commutated spherical motor pump, with an expected service life of well over 50,000 hours.

The only moving part in a spherical motor pump is a spherically shaped rotor/impeller unit, which is seated on an ultra-hard, wear-resistant ceramic ball. The conventional shaft, shaft bearings and shaft seals have been eliminated.

The spherical bearing of the rotor/impeller unit on the ceramic ball offers a number of advantages. One such advantage is that the occurrence of bearing play – and the associated increase in noise – is not possible due to the principle involved. Consequently, the pump continues to work quietly throughout its entire service life. The bearing is self-realigning. It is lubricated directly by the medium being pumped (wet rotor design). This means that the pump is maintenance-free. Since the rotor is always magnetically held in the designated position, small particles of dirt do not present a problem. Under normal conditions, it is impossible for the rotor to become locked. Reliable start is also ensured even after long periods of shutdown.

The permanent magnet rotor/impeller unit is driven by the magnetic field generated by the surrounding stator. The stator is wrapped entirely around the rotor. As a result, the entire pump is only slightly taller than the rotor itself, measuring only 1.5" in height. Accordingly, it fits easily into all standard computer cases.

The spherical motor design permits economical operation with comparatively high output. Supply voltage variation provides a simple means of controlling the speed of the DDC pump over a large output range. All parts in contact with the medium are 100% corrosion resistant. With an optional tachometer output, it is possible to monitor the speed of the pump directly. In many computers, the tachometer output can be connected to a fan connector.

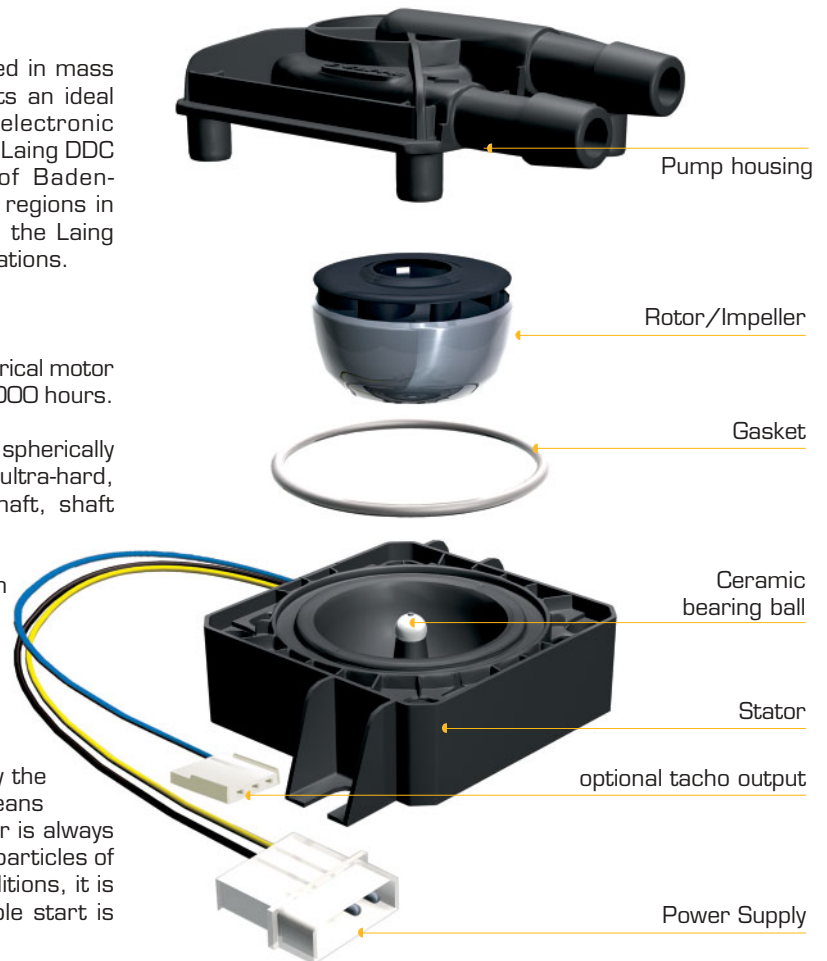

Technical Data

Motor design	Electronically commutated spherical motor
Rated voltage	12 Volt DC
Power consumption	DDC1: max. 12 Watt DDC2: max. 18 Watt
Voltage range	8 to 13,2 Volt*
Acceptable media	Water; Water-/Glycole Mixtures***, other media on request;
Max. system pressure	21.75 PSI
Max. system temperature	140° F
Wetted parts	Stainless steel 1.4571, PPS-GF40, EPDM gasket, Aluminium oxide, carbon; PA6.6 GF35

* minimum startup Voltage 9 Volt

** check pump performance for mixtures of 20% or more glycole

ddc DC pumps incl. 12 Volt power cord (2.4 ft)

Laing offers various models of the DDC pump.
Model designations*:



Model DDC-1 or
model DDC-2

T: tach output
blank: no tach output

P: plug
blank: no plug

MP: Mounting feet parallel
MC: Mounting feet cross
blank: no mounting feet

NPT: 1/4" NPT
blank: 3/8" hosebarb

*For OEM use Laing also offers DDC pumps with integrated pressurized volume compensator.
Please contact us for further information.

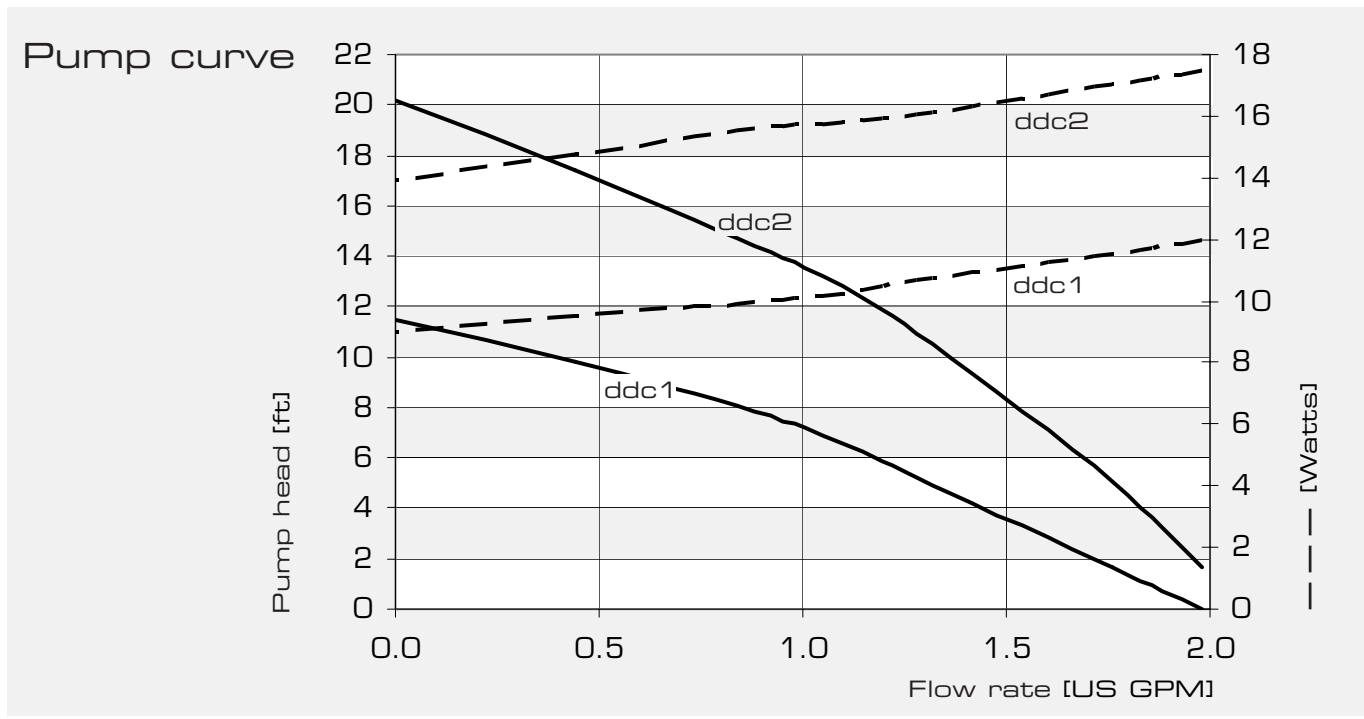

Dimensional drawings DC pumps Laing ddc1 and ddc2

With 3/8" hosebarb connection:

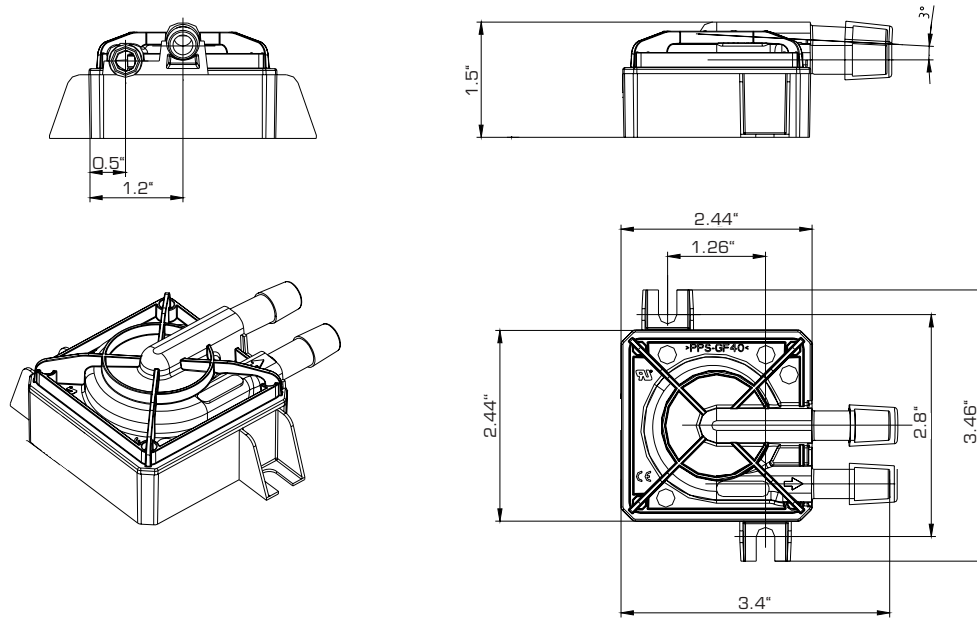

With 1/4" R male connection:

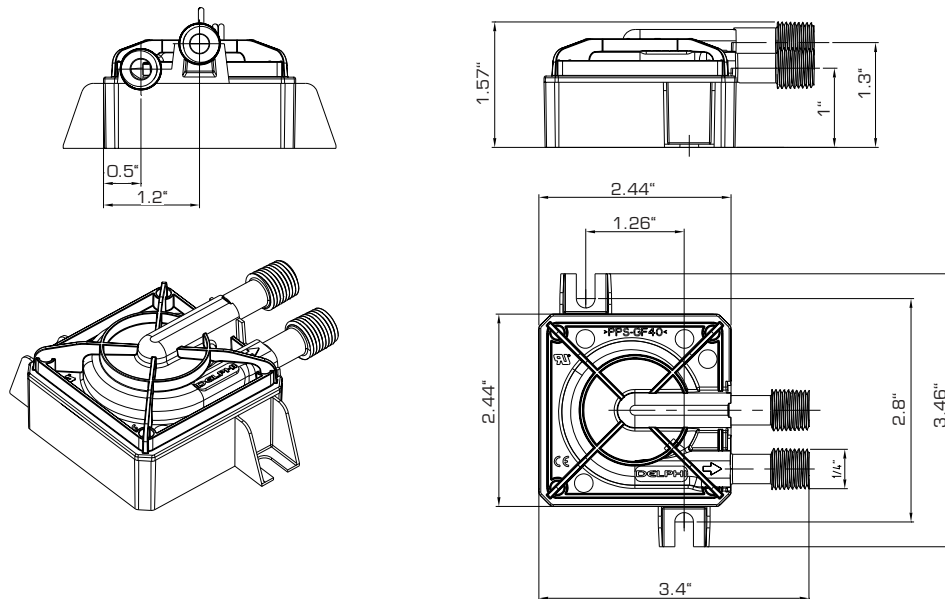

270706 Subject to change without notice

